

MODEL 6011 MK II
NISKIN WINGED CURRENT METER
OPERATING MANUAL
RAM MEMORY
OCTOBER 2000



General Oceanics Inc.
1295 N.W. 163rd Street
Miami, Florida 33169-5887
Fax: (305) 621-1710
Phone: (305) 621-2882
Email: Info@GeneralOceanics.com
[Http://www.GeneralOceanics.com](http://www.GeneralOceanics.com)

YOUR CURRENT NETER SHOULD BE RECEIVED WITH THE FOLLOWING ITEMS . PLEASE CHECK WHEN UPACKING TO BE SURE THEY ARE INCLUDED.

1. 6011MK2 CURRENT METER
2. VISIBLE SENSORS, PRESSURE & CONDUCTIVITY
3. WIRE MOORING STANDOFF FRAME (W./ANODES) AND WIRE STOP
- * 4. RAM MEMORY CARTRIDGE
5. OPERATORS MANUAL

* RAM MEMORY CARTRIDGES AND RAM READER KITS ARE PRICED SEPARATELY

IF ANY OF THE ITEMS ARE MISSING, PLEASE CONTACT G.O. ASAP

Table of Contents

1	INTRODUCTION	1
2	PRINCIPLES OF OPERATION	2
	2.1 Basis.....	2
	2.2 Vector Averaging.....	4
	2.3 Self test.....	6
3	CONTROLS AND INDICATORS	6
	3.1 User Operated Controls.....	6
	3.2 External ON.OFF Switch.....	6
	3.3 Sampling Interval.....	6
	3.4 Burst Length.....	8
	3.5 Burst Interval.....	8
	3.6 Trigger Reset.....	8
	3.7 Mode Selector.....	8
	3.8 Self –Test Lamp.....	9
	RAM MEMORY	9
	4.1 Introduction.....	9
	4.2 Cartridge Data Capacity.....	9
5	INSTRUMENT PREPARATION	10
	5.1 Battery Capacity.....	10
	5.2 Battery Replacement.....	10
	5.3 Switch Settings.....	10
	5.4 Sealing Up.....	11
	5.5 Deployment.....	11
	5.6 Fin Chang.....	11
6	DEPLOYMENT	11
	6.1 preparing for Deployment.....	11
	6.2 Unplugging the Cartridge.....	12
	6.3 Other Notes.....	12
	6.3 .1 Battery Life.....	12
	6.3.2 Last Record Data Loss.....	13
	6.3.3 Monitor Connector.....	13
	6.3.4 Serial Number Record.....	13
	6.3.5 Data Format.....	13
7	BATTERY	14
	7.1 Battery Safety.....	14
8	CAUTIONARY NOTES	15
	8.1 Choice of Sampling Interval.....	15
9	SPECIFICATIONS	16
10	MOORING METHODS	18
11	CALIBRATION CURVES	21
12	MAINTENANCE	28
	12.1 Routine Care.....	28
	12 .2 Antifouling Treatment.....	28

FIGURES

Fig.1 Simplified Program Flow Chart

Fig.2 Real-Time Clock, Block Diagram

Fig.3 Electronics Package

Fig.4 Deployment for Near-Bottom Measurement

Fig.5 Typical Deep-Sea Deployment

Fig.6 Calibration Curve
Low-Speed Fin: No Environmental Sensors

Fig.7 Calibration Curve
Low-Speed Fin with Conductivity

Fig.8 Calibration Curve
Standard Fin: No Environmental Sensors

Fig.9 Calibration Curve
Standard Fin with Conductivity

Fig.10 Calibration Curve
High-Speed Fin: No Environmental Sensors

Fig.11 Calibration Curve
High-Speed Fin with Conductivity

1 INTRODUCTION

The General Oceanics model 6011 MkII is a battery-powered RAM recording current meter. It measures current by measuring the angle of tilt of its own housing when suspended from a suitable mooring. Wings on the housing orient the meter with the current, the direction of which is then determined by a solid-state flux-gate compass. The absence of rotors and other delicate external sensors, together with its extremely low power consumption, make the meter ideal for long term deployments in the deep ocean, while its small size and ease of handling make it the choice for much inshore work.

The meter incorporates a real-time clock. This means that Universal Coordinated Time (GMT) is recorded with each data point on the RAM cartridge. Log keeping and data analysis are thereby simplified and there is less chance of ambiguity in interpreting the data record. The real-time clock is powered by its own battery, which is separate from the meter's main power battery, and which has a five-year lifetime.

The basic meter records temperature as well as the data for current speed and direction. Sensors to measure conductivity and pressure are also available as options.

In the "Vector-Averaging" mode, the internal microprocessor computes the average east and north components of current from a number of individual readings and records only those averages on the RAM cartridge, a data compression technique which increases the effective capacity of the cartridge by up to thirty-two times. The microprocessor also computes and records the standard deviation of the averages to provide information on the noise environment of the meter. Vector-averaging is the preferred mode of operation. It provides the maximum amount of data and requires the least amount of post-deployment data processing.

After the meter has been recovered the RAM cartridge must be processed. General Oceanics offers the service of reading RAM cartridges and supplying a complete range of data products. Alternatively, the user can acquire a model 6011RR RAM reader to interface with anyone of a range of desk-top computers, which allows the user to process the data himself.

General Oceanics can supply auxiliary hardware to facilitate deployment of the model 6011 current meter in a wide range of situations. Deployment from a fixed structure such as an oil rig or harbor pier is the easiest to set up. For near-bottom measurements, a "gallows" frame is available which provides a fixed point mooring at a known height in the water. Most deployments use a wire mooring with either a surface or sub-surface float. For this application a "stand-off" is used, which can be clamped to the wire at any depth without cutting or damaging the wire in any way. The stand-off not only keeps the meter clear of the wire, but also de-couples the meter from mooring motion. Both a stand-off and a wire stop are supplied with the meter.

The design of the stand-off and the operating principle of the meter itself both help to simplify mooring design. Being able to clamp the stand-off at any point along the wire makes it easy to re-configure a mooring to meet changing operational requirements. Also, since the meter takes up an angle of tilt determined only by the current, the tilt of the mooring itself is a secondary consideration. This means that, particularly in high current regimes, buoyancy requirements and anchor weights can be greatly reduced.

The meter is normally supplied with a standard fin which covers the speed range zero to 225 cm/sec. For

greater resolution at low speeds or to extend the range to higher speeds, low-speed and high-speed fins are available.

2 PRINCIPLES OF OPERATION

2.1 Basis

The Model 6011 MK II current meter is a microprocessor controlled data logger which captures data from a number of sensors and then records them on a RAM cartridge. The overall operation of the meter is best explained by the simplified program flow chart shown in Fig. 1.

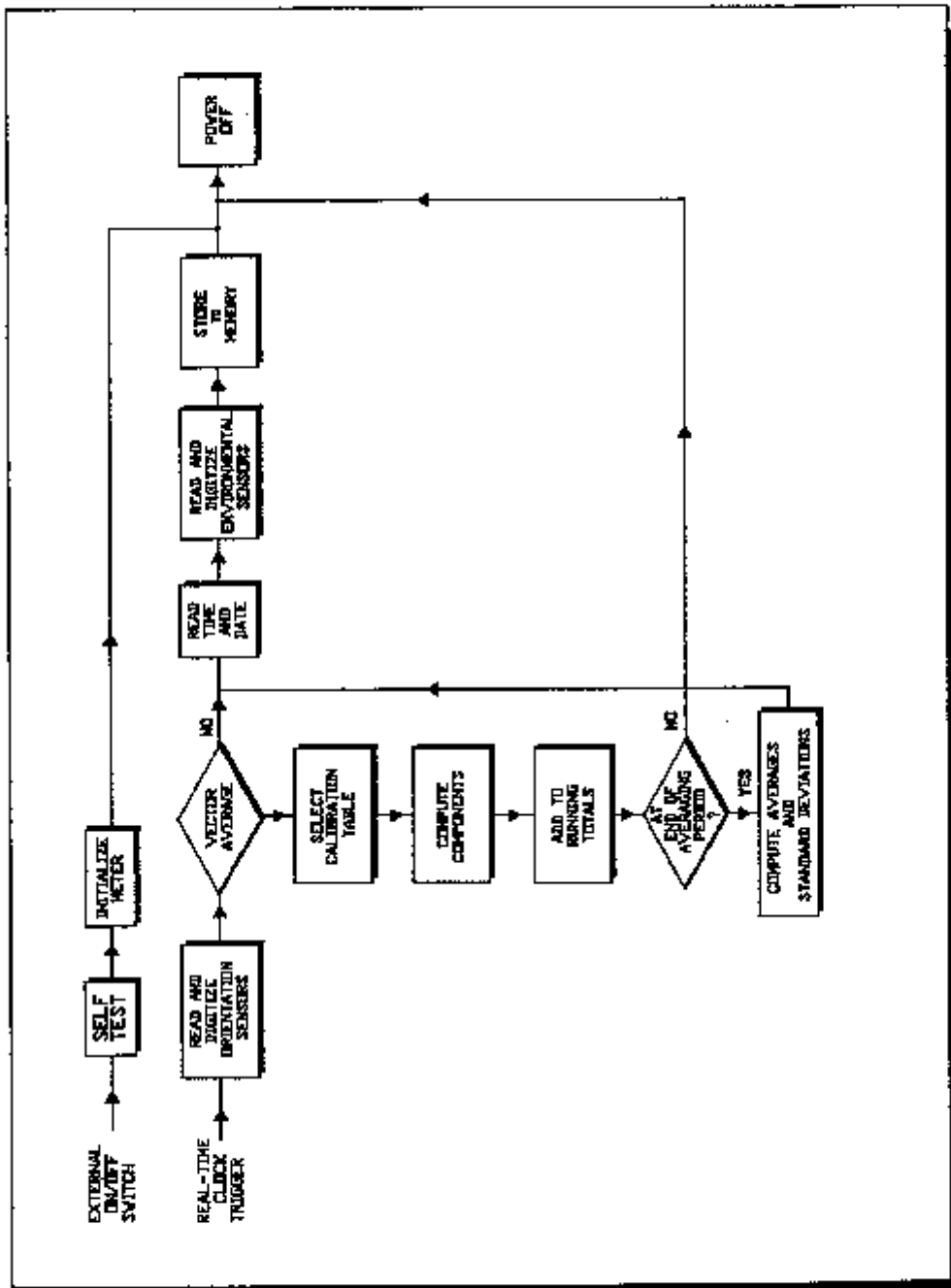

Fig.1 Simplified Program Flow Chart

2.2 Vector Averaging

In the vector-averaging mode, the microprocessor proceeds to compute the north and east components of current immediately after it has read the orientation sensors. To compute the components it needs to know which of the three fins are fitted to the meter. This information is provided by the setting of the mode selector switch: positions 2, 3 and 4 for vector averaging with low, standard and high speed fins. The number of samples over which the average is taken is determined by the setting of the samples-per-burst switch on the real-time clock board. As shown in Fig. 2, a line called "burst status" remains low during the burst period. All the time the status line is low, each component is added to a running total. If it is high, signaling the end of the averaging period, the running total is divided by the number of samples to arrive at the average. Standard deviation is treated in a similar way. The meter then goes on to read the real-time clock and the outputs of the environmental sensors. Each reading is tagged with time and recorded to RAM. Finally the meter is powered down. This means that battery power to the sensors and any other high current components is switched off; only the essential time-keeping components and some of the data memory remain operating. Hence, current consumption between samples is reduced to a few micro amps, allowing the meter to operate for up to one year on a single battery. One can see from the last part of the flow chart that time, date and the readings of the environmental sensors that are recorded correspond to the LAST of the samples used to form the vector averages of current, a point that may be significant in data interpretation.

Calibration tables for all three fins are stored in the meter so that if a fin is changed it is necessary to set the mode selector switch to the new position. The tables for meters fitted with pressure and conductivity sensors are slightly different from those without.

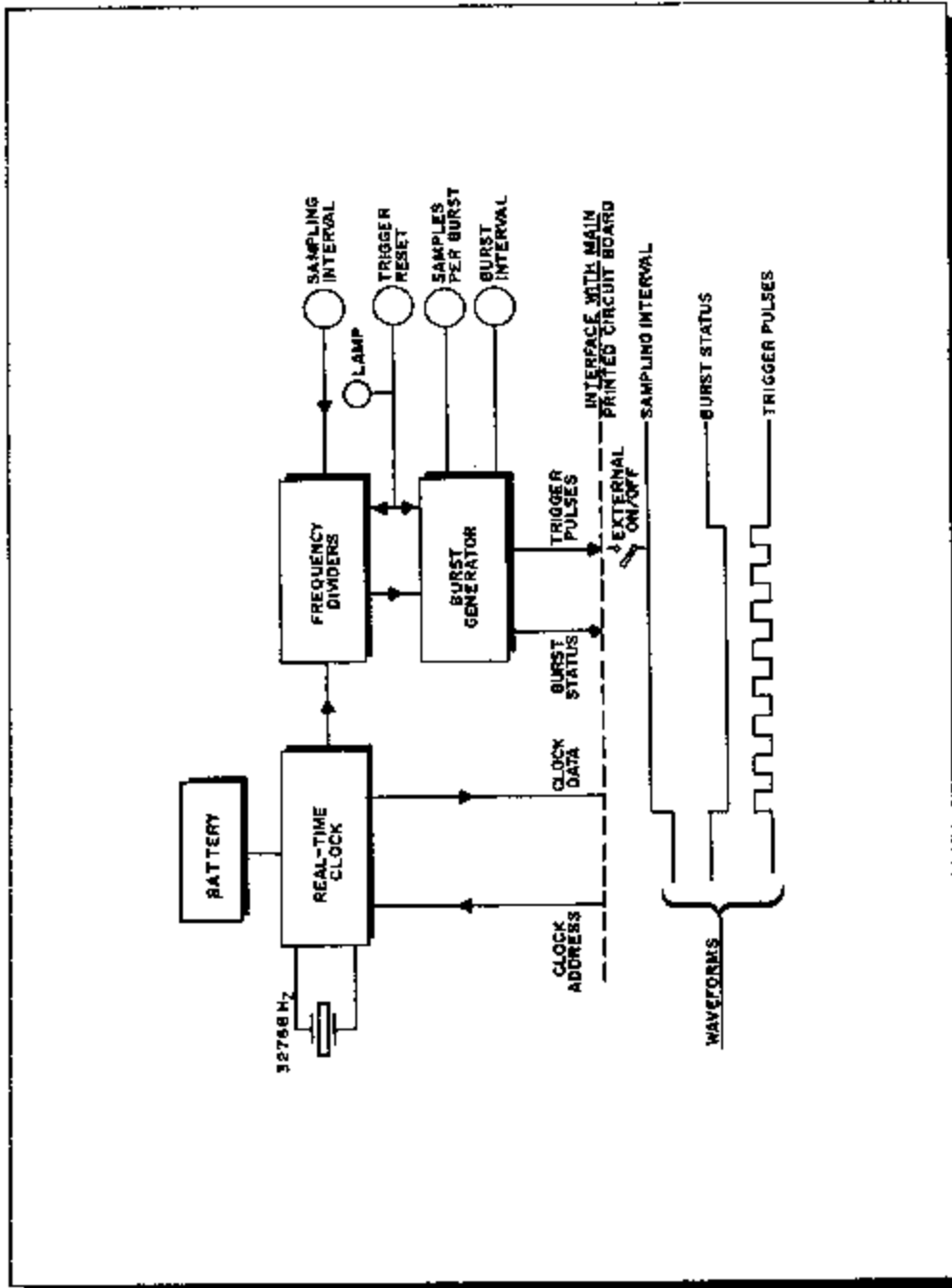

Fig.2 Real-Time Clock.
Block Diagram

2.3 Self test

An external ON/OFF switch is mounted on the end cap of the meter's pressure housing. As the hardware block diagram in Fig. 2 indicates, when the switch is in the ON position trigger pulses from the real-time clock are allowed to reach the power control circuitry and the meter cycles through its measuring and recording functions as already described. In the OFF position the meter remains in the quiescent, low power, condition. Turning the switch from OFF to ON triggers a self-test and initialization sequence.

3 CONTROLS AND INDICATORS

3.1 User Operated Controls

The Model 6011 Mk II current meter has a number of user-operated controls which select the various operating modes and sampling intervals. Most of the controls are mounted on the main printed circuit boards (see Fig.3) and are accessible only when the meter is withdrawn from its pressure case. The one external switch is mounted on the end cap opposite to the swivel end. Conductivity and pressure sensors, when fitted, are mounted on the same end cap.

3.2 External ON/OFF Switch

This rotary action switch controls the flow of trigger pulses from the clock board to the main board. In the OFF position no pulses get through and the meter remains in its standby state drawing minimum battery current. In the ON position the meter is triggered into operation at the rate set by the sampling-interval and burst-sampling switches. If the meter is out of its pressure case, the successful progress of the routine can be followed by counting the eight flashes of the self-test lamp.

Normally, this switch will be turned ON or OFF once or twice as part of the check out procedure and then left OFF until just before deployment.

3.3 Sampling Interval

This switch sets the basic sampling interval of the meter in all its operating modes. Operated with the aid of a small screwdriver, this 10-position switch selects intervals from 7.5 seconds to 60 minutes. See SPECIFICATIONS for the full range of available intervals.

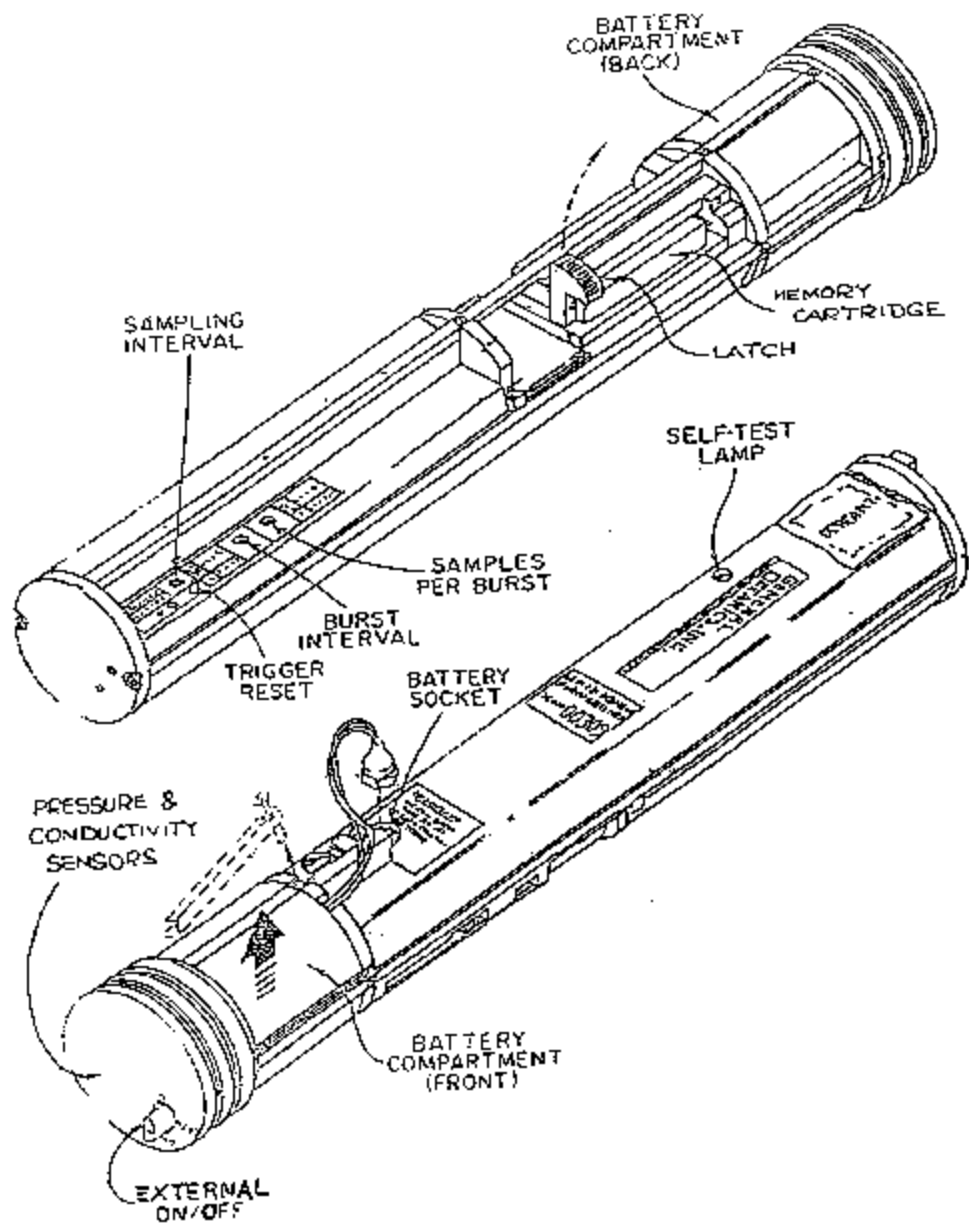

Fig.3 Layout of main features and controls

3.4 Burst Length

A 6-position switch selects the number of samples in a burst. The numbers available are one to 32 in 1:2 steps. This switch selects the number of samples over which the average is taken. In position six, for example, a burst of 32 samples will be averaged before being recorded as a single value. With the switch in position one, the burst length is a single sample.

3.5 Burst Interval

A 4-position switch determines the interval between the samples to be used in a vector average. Thus, if a burst of eight samples and an interval of four seconds are selected, the effective averaging period will be 32 seconds.

3.6 Trigger Reset

Pressing this button resets the counting circuitry so that trigger pulses can be made to occur at a known time in each hour. The general rule is that the first trigger pulse occurs at a time one half of the selected sampling interval after pressing the reset button. If a sampling interval of one minute has been selected, for example, then the first trigger will occur 30 seconds after pressing the trigger reset button, the next at one minute and thirty seconds, the next at two minutes and 30 seconds and so on. The general rule does not apply for the 30 and 60 minute sampling intervals. In both cases the first trigger occurs 22.5 minutes after reset; all the following ones are at the selected intervals.

The red indicator lamp next to the button provides a positive indication that reset has occurred.

The push-button has no effect on the setting of the real-time clock.

3.7 Mode Selector

This switch, mounted on the opposite side of the meter from the other four controls, determines the vector-averaging mode. Position 1 is for factory use. Positions 2, 3 and 4 select the vector averaging mode. position 2 should be used if a low-speed fin is fitted to the meter, 3 for a standard fin and 4 for a high-speed fin. When computing the vector averages, the microprocessor examines the switch setting in order to select the correct fin calibration look-up table.

3.8 Self-Test Lamp

When the meter self-test is triggered by actuating the external ON/OFF switch, this lamp flashes at the rate of eight times in three seconds as the test proceeds.

4 RAM MEMORY OPERATION

4.1 Introduction

RAM Memory is a solid-state memory system which replaces the more traditional tape recorder and data cassette for long term storage of the data gathered by the current meter. It makes use of a removable data cartridge containing its own 10-year battery power source. The cartridge is smaller than a standard audio cassette, offers up to twice the data capacity, and can be quickly and conveniently changed in the field with no external equipment.

The design of the RAM Memory incorporates a number of features to ensure that recording will take place reliably during a deployment and that data cannot be accidentally erased after a recovery of the meter. For instance, a mechanical interlock prevents the user closing the pressure housing if the cartridge is incorrectly seated in its holder and a self test procedure warns if the cartridge's internal battery has run down. After recovery, a write-protect switch on the cartridge can be set, thus making it almost impossible to inadvertently erase the stored data.

A simple reader is available (6011RR) which plugs into an expansion slot of an I.B.M.* P.C. or PC/XT desktop computer. This, together with software which is supplied by General Oceanics, allows the user to read and process the data stored in the cartridge.

*Registered trademark of International Business Machines Corporation.

4.2 Cartridge Data Capacity

Cartridges are available in nominal capacities of 64, 128, 256 and 512 kilobytes. Each data record in the meter is stored as a 13-byte word. In addition, 13 bytes are used to store the instrument serial number together with some information used internally by the meter itself. Taking as an example a 128 kbyte cartridge, we can now calculate its capacity in terms of data records. The actual size of the cartridge is 131,072 bytes. This leaves 131,059 bytes for useful data, which is equivalent to

10,081 complete data records. The corresponding figures for the other sizes are 5,040, 20,163 and 40,328 data records. The largest capacity cartridge, therefore, allows recording once every ten minutes for almost a full year.

5 INSTRUMENT PREPARATION

5.1 Battery Capacity

First check that there is sufficient battery capacity remaining to run the instrument for the planned deployment period. The only way to be sure of this is by keeping an accurate record of battery use on the label provided on the side of the battery. If there is any doubt, use a new battery. (Refer to section 6.3.1 Battery Life.)

5.2 Battery Replacement

The actual removal and replacement of the battery is very straight forward. The gray plastic battery holder is held in place by a short retaining bar which is secured with a single captive screw. Battery connection is via the blue 5-pin connector at the end of the short pigtail. As the battery holder is being slid into position, take care to guide the pigtail into the slot provided.

5.3 Switch Settings

First select the mode, selector switch. If vector averaging then make sure the switch points to the correct fin. Then set the burst-interval and samples-per-burst switches for the desired averaging period. Thirdly, bearing in mind the constraints pointed out in paragraph 8., select the sampling interval to match the planned deployment period. Finally, press the trigger reset button to lock the triggering sequence in the right phase with the real-time clock.

Again, for many applications, averaging over 32 samples at 2-second intervals (Samples-per-Burst=32: Burst Interval=2sec.) provides good coverage. The sampling interval can be set anywhere between 2 minutes and 30 minutes, depending on the duration of the deployment.

When the instrument has been prepared as just described, activate the external ON/OFF switch to trigger the self test sequence (eight flashes of the self test lamp). Some practice may be needed in positioning the meter so that the self-test lamp can be observed while activating the external switch. If all is well at this stage the switch should be turned off and the meter sealed in its pressure housing.

5.4 Sealing Up

The important points at this stage are (1) place a desiccant bag in the pressure housing, and (2) make sure that the single O-ring seal, and its mating surface, are clean, lightly greased and undamaged. CHECK THAT THE SERIAL NUMBER OF THE HOUSING MATCHES THAT OF THE METER'S ELECTRONICS. Slide the meter carefully into the housing, checking that the battery pigtail is tucked out of the way. Turn the meter so that the alignment hole in the end cap matches the one in the housing. As the meter is driven home, the pin at the end of the meter should engage the locating hole in the far end cap. Secure the meter using the thick nylon monofilament locking cord. It should slide into the matching half-grooves in the end cap and the pressure housing until only the L-shaped termination is exposed. The short end of the L is then pressed into the aligned holes. This ensures that the meter's internal sensors are lined up with the center line of the fin.

5.5 Deployment

After the meter has been prepared as described in the foregoing paragraphs, all that remains is to TURN THE EXTERNAL SWITCH ON and attach the meter to the mooring.

5.6 Fin Change

If the meter is to be used in areas where very high or very low currents are expected, the standard fin can be replaced by one with the appropriate range (see SPECIFICATIONS for ranges available). The fin is secured by two cable ties which rest in grooves in the pressure housing (see section 12.3 for part numbers of replacement ties). The fin is aligned with the meter's direction sensors by the nylon bolt at the swivel end of the housing; the bolt is in turn secured by a locking screw in one of the lugs of the end cap. Note that although the fin can be changed, THE PRESSURE HOUSING AND ELECTRONICS PACKAGE MUST STAY TOGETHER AS A PAIR TO PRESERVE THE ACCURACY OF CALIBRATION.

6 DEPLOYMENT

6.1 Preparing for Deployment

In preparing a meter the user should, in general, follow the procedures detailed in Section 5 (INSTRUMENT PREPARATION) of the Operating Manual.

The mode selector switch (described in section 3.7) should be set to position 2, 3, or 4 depending on whether a low, standard or high speed fin is fitted to the meter.

Fig.1 shows the RAM Memory cartridge in place in the current meter. To plug in the cartridge simply lift the latch, turn the cartridge so the write-protect switch faces outwards, and insert it into the 30-pin socket. If the cartridge is not properly seated, the latch will not spring back to its fully closed position and it will be impossible to slide the meter into the pressure housing.

Finally, set the write-protect switch on the cartridge to OFF, plug in the battery, and turn on the external ON/OFF switch. The meter will then go through a self-test routine as indicated by the Self-Test lamp flashing eight times. If the lamp does not flash, check that the cartridge is properly plugged in with the write-protect switch off.

6.2 Unplugging the Cartridge

When the current meter is recovered at the end of a deployment it will be necessary to remove the cartridge from the meter in order to read it. The cartridge is so designed that it is very difficult to lose or alter the stored data while unplugging it. However, to be absolutely sure, the following procedures should be followed:

- a)As the meter arrives on deck set the External ON/OFF switch to the OFF position and note the time.
- b)Rinse with fresh water and dry the meter as usual.
- c)Remove the meter from the pressure housing.
- d)Set the write-protect switch on the RAM cartridge to the ON position.
- e)Unplug the battery.
- f)Lift the latch (see Fig 1) and remove the cartridge from its socket.

All the time the cartridge is out of the meter the write-protect switch should be left in the ON position.

6.3 Other Notes

6.3.1 Battery Life

RAM Memory draws less power from the battery allowing more readings to be taken. For instance, when taking 32-sample averages, the battery has enough energy for 40,000 32-sample averages. So, the maximum deployment time is one year OR the time to record 40,000 32-sample averages OR 80,000 16-sample averages OR 160,000 8-sample averages, whichever is the shortest. Note that the 40,000 averages could be recorded in a single deployment using a 512 kbyte cartridge or in a series of deployments using a 128 kbyte cartridge several times.

6.3.2 Last Record Data Loss

The RAM Memory system can lose some data as a result of the averaging process itself. For example in the process of assembling a 32-reading average, the meter is switched off just before taking the 32nd reading 31 data points have been lost.

6.3.3 Monitor Connector

The monitor connector is disabled except for the manufacturer's use. To check out a meter, it is a simple matter to record a few minutes' worth of data and then read the cartridge.

6.3.4 Serial Number Record

The first two bytes in the RAM Memory cartridge are used to record the meter's full serial number.

6.3.5 Data Format

Data within the meter are handled as binary numbers, each having sufficient bits to match the required precision. As the data are prepared for recording the individual numbers are stacked end to end to form a string 104 bits long. During the recording process itself the string of bits is stored in the RAM Memory cartridge eight bits at a time as 13 bytes. The bits for each record are organized as follows in the order shown:

<u>Data</u>		<u>Number of Bits</u>
Month		4
Day		5
Hour		6
Minute	12	
Pressure		12
Temperature		12
Conductivity		12
East current component		12
West current component		12
Standard deviation in east component	12	
Standard deviation in west component	12	
	Total	<hr/> 104

The way in which each piece of data is encoded and the significance of each bit in the record are as follows:

Number of bits	Vector Averaging
1	1
7	Serial Number
4	Month
5	Day
5	Hour
6	Minute
12	Pressure
12	Temperature
12	Conductivity
12	East Component
12	North Component
12	E. Std. Deviation
12	N. Std. Deviation
<hr/>	
112	

7 BATTERY

7.1 Battery Safety

Lithium batteries store a large amount of energy in a small volume so they should always be handled with care. The following rules should be followed:

DO NOT incinerate, short circuit, puncture, crush or disassemble the battery.

DO NOT attempt to re-charge the battery.

DO NOT store or use the battery at temperatures above 72 deg. C.

8 CAUTIONARY NOTES

8.1 Choice of Sampling Interval

When vector averaging, the sampling interval must be long enough to allow the meter to complete its cycle of operation. For example, if a burst length of 32 samples is selected together with a burst interval of two seconds the cycle takes almost 64 seconds to complete. In this case the sampling interval should be no less than two minutes.

(since the next shortest interval, one minute, is insufficient to accommodate the complete cycle).

If too short an interval is inadvertently selected, the meter automatically compensates, for many combinations of burst length and burst interval, by ignoring the intermediate trigger pulses. However, at best, this can only complicate later interpretation of the data record.

9 SPECIFICATIONS

Speed:

Sensor: Force-balance tilt sensor.

Range: 0 to 300 cm/sec. (with appropriate fin) Accuracy: +/- 1 cm/sec.

Resolution: +/- 1 cm/sec.

Direction:

Sensor: Three-axis flux-gate compass

Accuracy: +/- 2 degrees.

Resolution: +/- 1 degree.

Temperature:

Sensor: Aged linear thermistor

(Yellow Springs Instrument Co. Type 44202)

Range: -5 to +45 degrees C.

Accuracy: +/- 0.25 Degree C.

Resolution: +/- 1/64 Degree C.

Thermal time constant: < 2 MINUTES

Conductivity:

Sensor: Inductive Toroid

Range: 0 to 75 mS/cm.

Accuracy: +/- 2.5 mS/cm.

Resolution: +/- 0.1 mS/cm.

Pressure:

Sensor: Strain gauge.

Range: 0 to 10,000 p.s.i.

Accuracy: +/- 0.5%

Resolution: +/- 0.1%

Internal clock:

Type: Quartz crystal.

Accuracy: +/- 0.1 second/day

Outputs: Trigger pulses. Date and time information.

Power: Lithium battery independent of meter's main battery.

Battery life: 5 years.

Sampling interval:

Selected by 10-position switch.

Available intervals: 7.5, 15, 30, 60 seconds,
2, 5, 10, 20, 30, 60 minutes.

Burst sampling:

Samples per burst selected by 6-position switch;

2, 4, 8, 16, 32 samples per burst.

Burst interval selected by 4-position switch;

2, 4, 8, and 16 seconds.

Data capacity:

Cartridges are available in nominal capacities of 64, 128, 256 and 512 kilobytes. Each data record in the meter is stored as a 13-byte word. In addition, 13 bytes are used to store the instrument serial number together with some information used internally by the meter itself. Taking as an example a 128 kbyte cartridge, we can now calculate its capacity in terms of data records. The actual size of the cartridge is 131,072 bytes. This leaves 131,059 bytes for useful data, which is equivalent to 10,081 complete data records. The corresponding figures for the other sizes 5,040, 20,163 and 40,328 data records. The largest capacity cartridge, therefore, allows recording once every ten minutes for almost a full year.

Data translation:

Using Model 6011RR reader with desk-top computer {e.g., I.B.M. *P. C. or compatible).

Battery:

Two D-size lithium cells with capacity of 14 amp-hours.

Output: 7.8 volts

Life: up to one year, depending on operating mode.

Pressure case dimensions:

Length: 54.9cm. Diameter: 10.5cm

Weights:

In air: 9/0 Kg. In Water: 4.5Kg.

Pressure Seal:

Single O-ring.

Tool-free opening and closing using General Oceanics' standard plastic cord sealing system.

Exposed material:

Plastic and hard-coat anodized dichromate sealed aluminum.

Wing characteristics:

Low speed: 0 to 70 cm/sec.

Standard: 0 to 225 cm/sec.

High speed: 0 to 300 cm/sec.

10 MOORING METHODS

Figs. 4 and 5 illustrate possible ways of deploying the Model 6011 MkII current meter. Its lightness and compactness considerably ease the expense and difficulty of designing moorings. In deep-sea moorings, especially, the savings are enhanced by the reduced requirements in floatation, anchor weight and cable size.

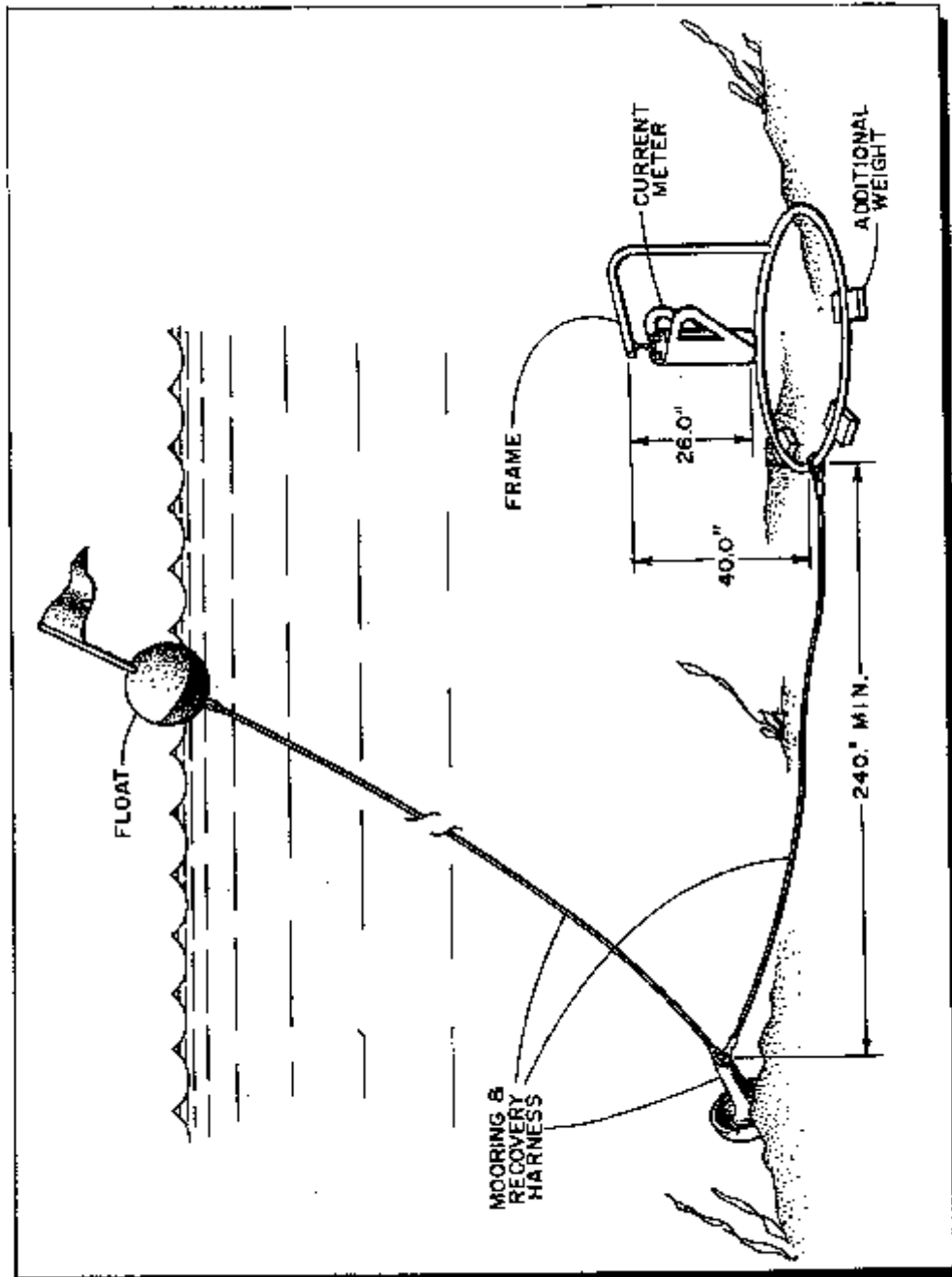

Fig. 4 Deployment for Near-Bottom Measurements

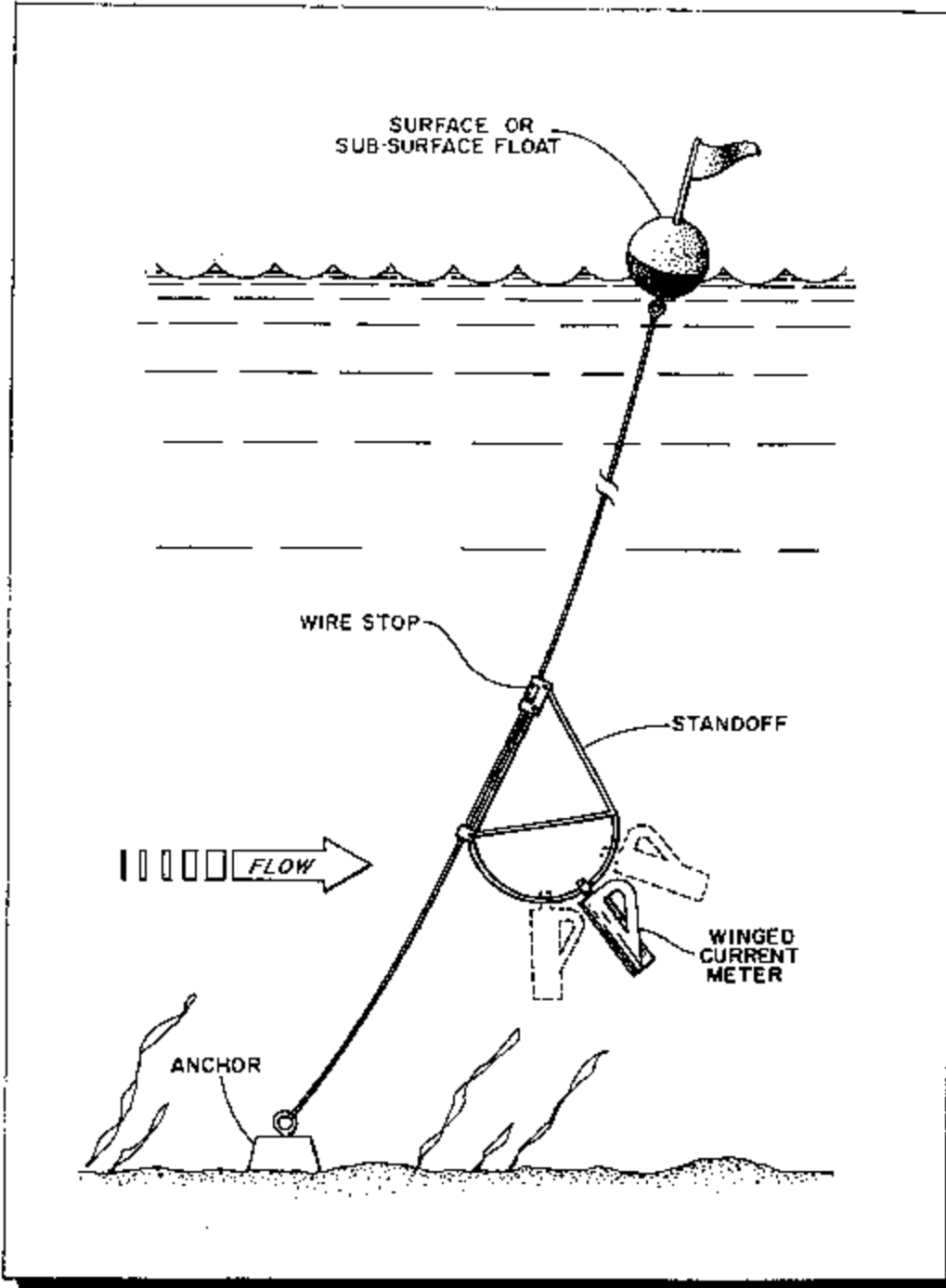

Fig.5 Typical Deep-Sea Deployment

11 CALIBRATION CURVES

On the following pages are six calibration curves showing tilt angle as a function of current speed for the low-speed, standard and high-speed fins. For each speed there are two curves. One is for meters that have no environmental sensors the other is for meters fitted with a conductivity sensor. The addition of a pressure sensor does not change either calibration curve. A temperature sensor is fitted to all model 6011 meters but since it is buried in the end cap, it too has no effect on the calibration curves.

Model 6011 Calibration Curve

Low Speed Fin; No Environmental Sensors

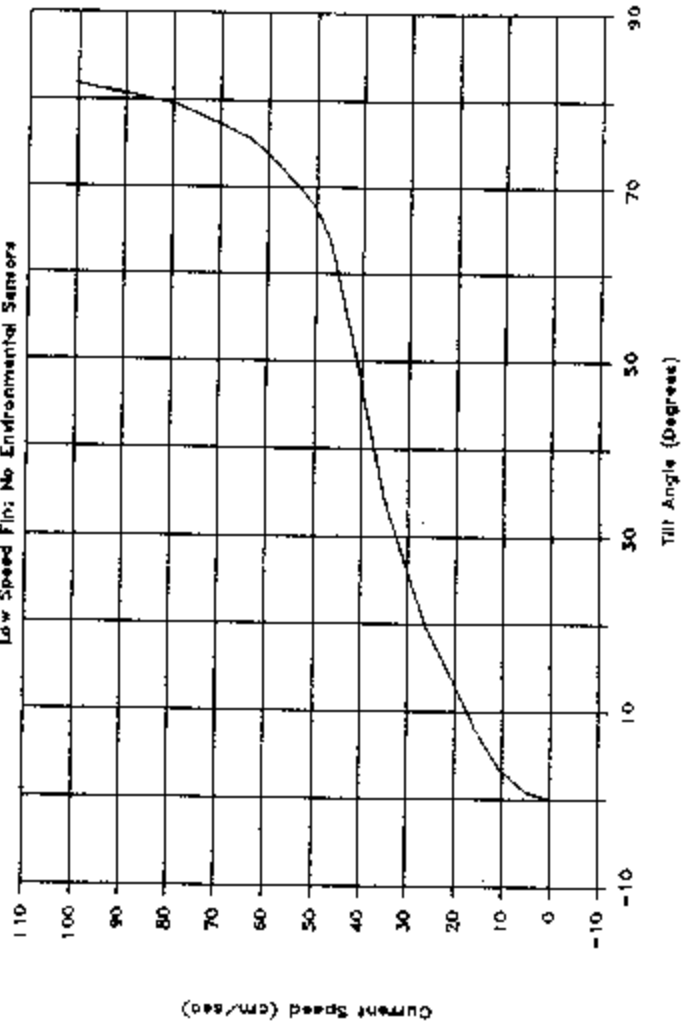

Fig. 6 Calibration Curve
Low-Speed Fin; No Environmental Sensors

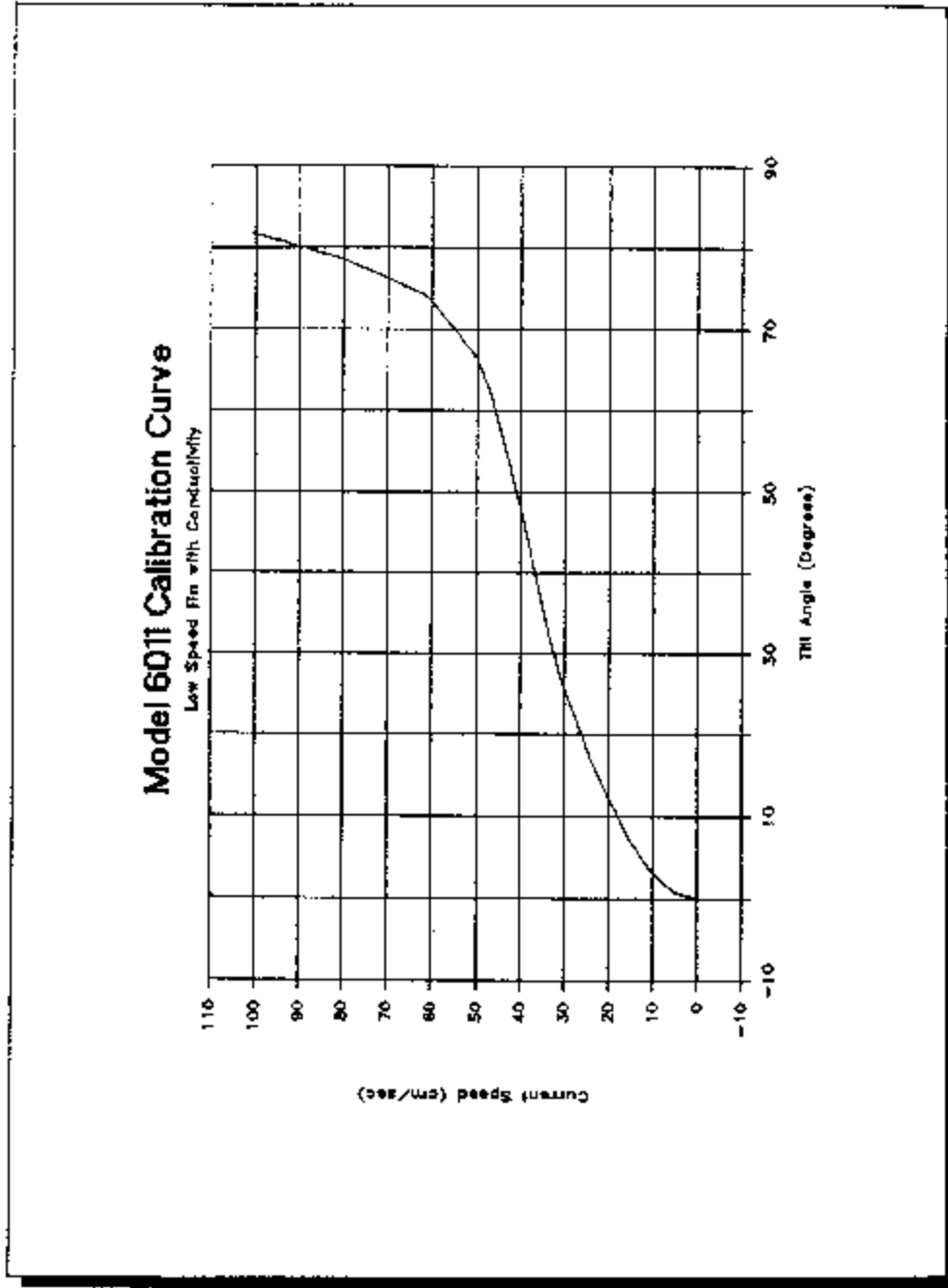

Fig.7 Calibration Curve
Low-Speed Fin with Conductivity

Model 6011 Calibration Curve

Standard Fin; no Environmental Sensors

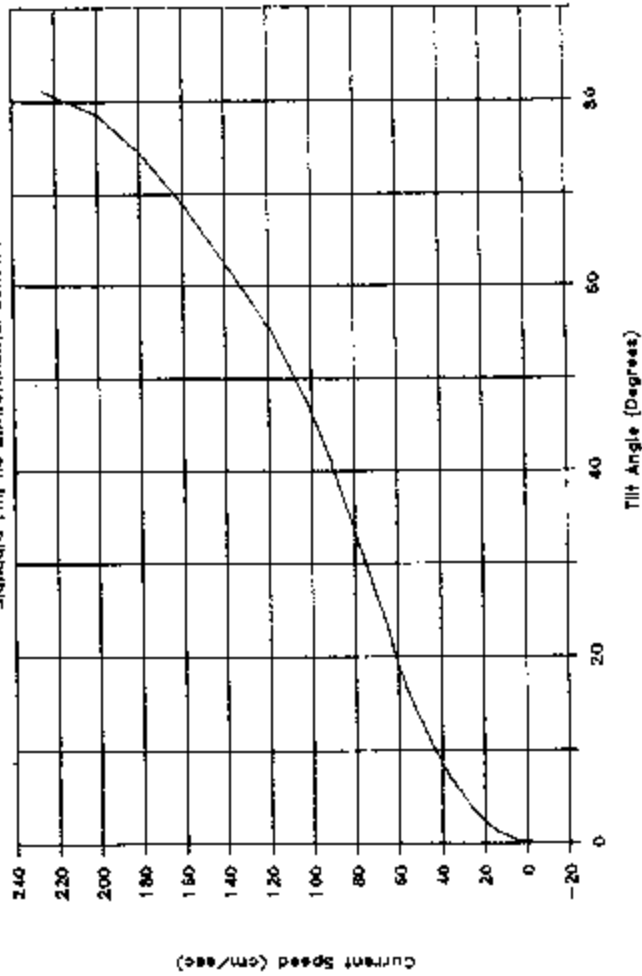

Fig. 8 Calibration Curve
Standard Fin; No Environmental Sensors

Model 60M Calibration Curve

Standard Fin with Conductivity

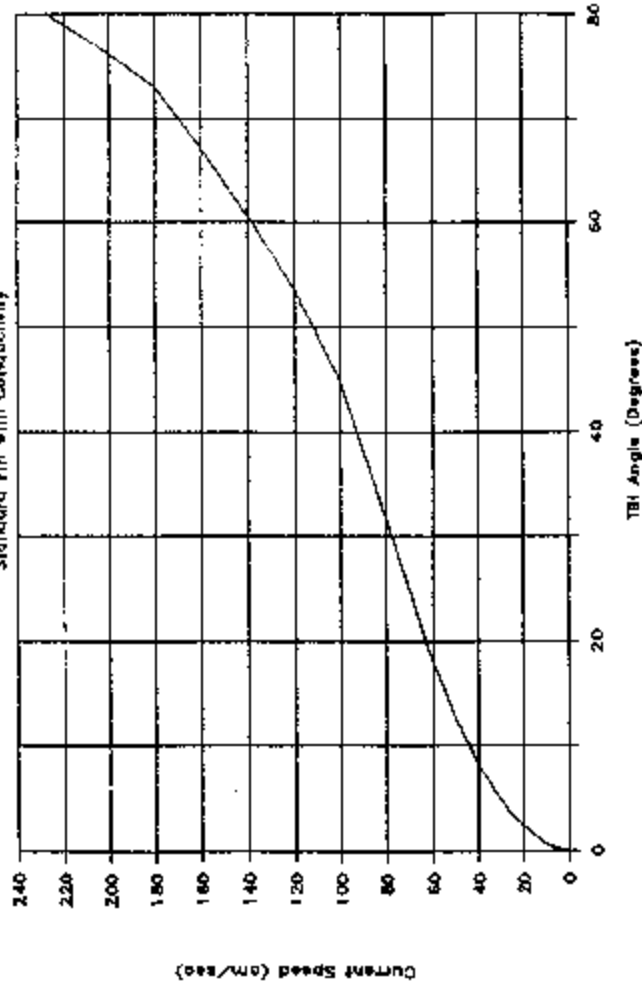

Fig.9 Calibration Curve
Standard Fin with Conductivity

Model 60M Calibration Curve

High Spd. Fins: No Environmental Sensors

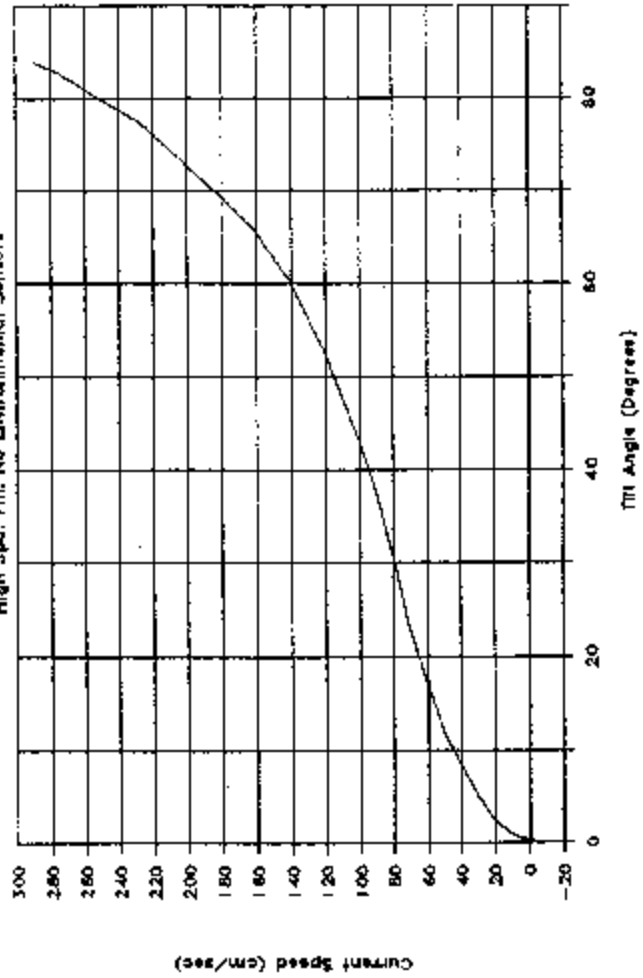

Fig.10 Calibration Curve
High-Speed Fins: No Environmental Sensors

Model 6011 Calibration Curve

High Speed Fin with Conductivity

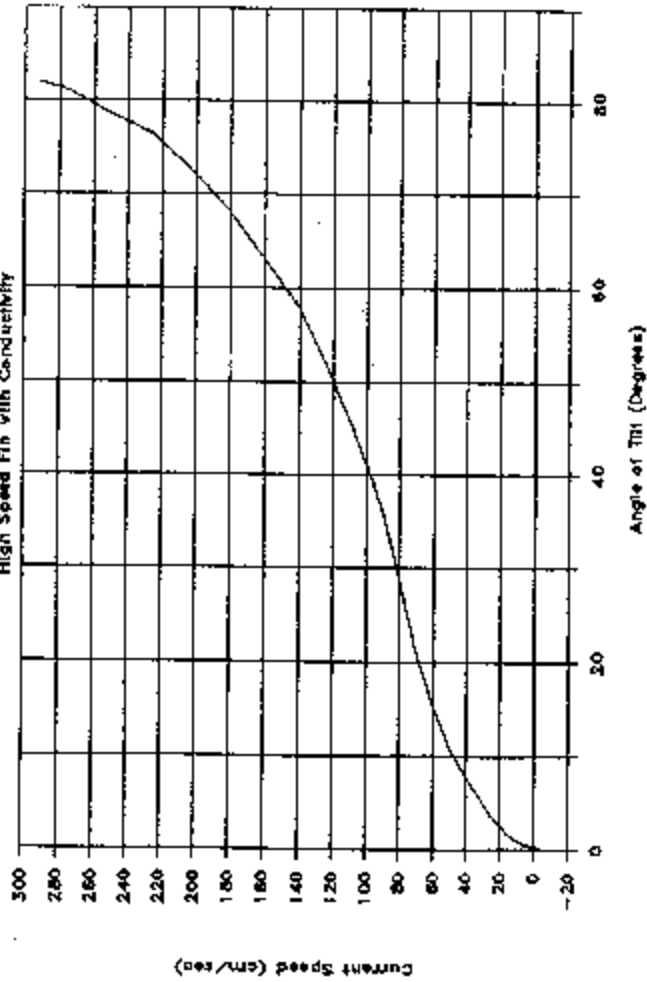

Fig. 11 Calibration Curve
High-Speed Fin with Conductivity

12 MAINTENANCE

12.1 Routine Care

Because of its simple design, the Model 6011 requires very little in the way of routine maintenance. The main battery should be replaced as recommended in section 6.3.1 of this manual. The batteries in the real-time clock have a life of five years. Changing these batteries entails removing the protective covers and re-setting the clock using special equipment available only at the factory. For this reason, it is recommended that meters be returned to General Oceanics, Inc. when the clock batteries become due for replacement.

Before each deployment, lightly grease the o-ring seals and check them for damage. If there is any doubt about their integrity, they should be replaced. After a deployment, remove any marine growth, exercising special care in the region of the conductivity and pressure sensors, and thoroughly rinse the meter in fresh water. Remove the main battery and store it separately if the meter is left unused for more than a few weeks.

12.2 Antifouling Treatment

To protect it against marine growth during extended deployments, the meter can be treated with anti-fouling paint. The following procedure uses material which are readily available at boat supply stores and which are compatible with the aluminum of the pressure case and the plastics of the fins. The layers of paint have a negligible effect on meter calibration.

Step 1: Clean housing thoroughly with hot, soapy water and rinse. Allow to dry and wipe thoroughly with acetone to degrease surface.

Step 2: Remove the ABS wing from the current meter pressure housing. Then apply two thin coats of Pettit Metal Primer to the pressure housing, allowing at least 2 hours drying time between coats.

Step 3: Apply two thin coats of Pettit Vinyl Red Undercoater. This forms the prime barrier to protect the aluminum. It is important that two thin coats, instead of one thick one, be used to ensure total coverage of the aluminum. Also apply two coats of undercoater to the ABS wing to ensure better adhesion of the antifouling coating. Remember to leave at least 2 hours between coats. If possible, apply the undercoater with a sprayer. For thinning and cleaning use Pettit # 140 Vinyl Thinner.

Step 4: Applying the antifoulant. Pettit Alumiguard is recommended because of its compatibility with aluminum. The current meter may be painted then shelved for up to 3 months without the treatment losing its effectiveness. Two or more thin coats should be applied; if expected use is in a high growth area put on up to 5 thin coats. Recoat time is from 1 to 4 hours. wait at least 16 hours after the last coat before immersion. Remember to coat the wing when using the antifoulant. Pettit # 140 Vinyl Thinner is used to thin the paint and for cleanup.

12.3 Spare Parts

The following are the General Oceanics reference numbers to the more frequently used spare parts.

<u>Item</u>	<u>G.O. Reference #</u>
Standoff	6011SO
Wire Stop	6011WS
O-ring	81-0153
Desiccant bag	99-0611
Cable tie - fin	48-1225
High-speed wing	6011000004
Low-speed wing	6011000003
Standard wing	6011000002
Battery	6011BL